

Note that all unique customer requirements (i.e tolerance) need to be verified thru Alfa Laval.

H 34
Alloy 304
S4

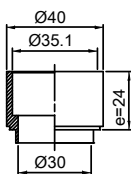

H 38
Alloy 304
S1,S2

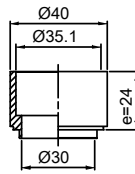

N 60
Alloy 304
S3

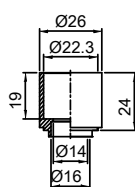

HEATING SURFACE
NETWEIGHT 18.9 kg
OPERATING WEIGHT
PLATE MATERIAL Alloy 316
PLATE GROUPING 1*44ML/1*45MH

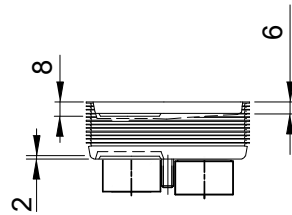
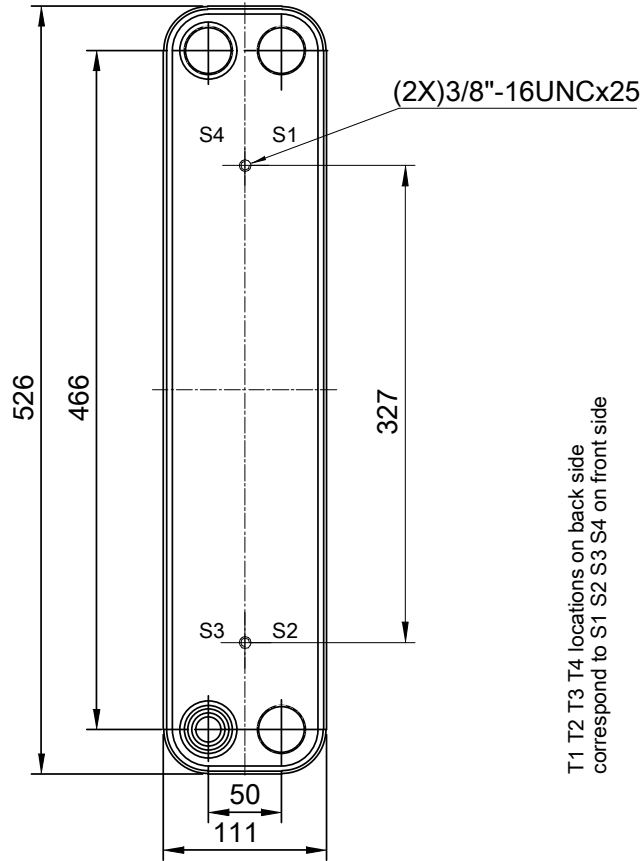
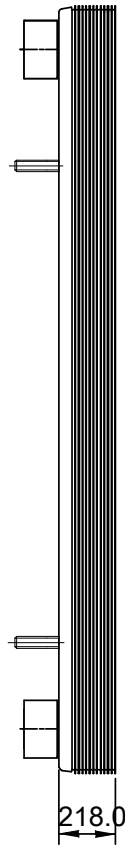

T1 T2 T3 T4 locations on back side correspond to S1 S2 S3 S4 on front side

ALL DIMENSIONS IN MILLIMETERS

SIDE	MEDIA	INLET	TEMP.	OUTLET	TEMP.	FLOW RATE	PRESSURE DROP	LIQUID VOL.
1								4.18 dm ³
2								4.28 dm ³

PRESSURE VESSEL APPROVAL

UL/CRN

ACH-70X-90M R49 (3287083726)

www.alfalaval.com

CUSTOMER NAME / REF. NO.

TOTAL LENGTH 244.0 mm
TOTAL WIDTH 111.0 mm
TOTAL HEIGHT 526.0 mm

COMPANY / REF.

6/5/2017
REV 0